

# 25TR



Concrete solutions. Always.

Engine D1105

Engine power 15.4 kW - 20.9 HP

Transport weight 2,320 - 2,450 kg

 **EUROCOMACH**<sup>®</sup>

# 25TR

Transport weight with canopy (without bucket and operator)	kg	2320
Transport weight with cabin (without bucket and operator)	kg	2450
Operating weight ISO 6016 with canopy (with bucket 55 kg and operator 75 kg)	kg	2480
Operating weight ISO 6016 with cabin (with bucket 55 kg and operator 75 kg)	kg	2580
Travelling speed	km/h	1a : 0 ÷ 2.6 / 2a : 0 ÷ 4.0
Slew speed	rpm	10,5

## ENGINE

Type	<b>KUBOTA D1105 - STAGE 5</b>	
Max. Power (2.400 rpm)	kW - HP	15.4 - 20.9
Displacement	cc	1105
Number of cylinders	n°	3
Cooling	Liquid	
Consumption	lt/h	3
Alternator	V (A)	12 (40)
Battery	V (Ah)	12 (62)

## HYDRAULIC SYSTEM

Circuit Type	Load Sensing closed center system with "Flow Sharing" control valve	
Pump type	1 LS variable pump + 1 gear pump	
Pump displacement	cc	25 + 4.95
Pump capacity	lt/min	52 + 10.3
Max. circuit calibration pressure	bar	240
Auxiliary system (max pressure): AUX 1 single or double effect with priority	lt/min (bar)	50 (200)

## PERFORMANCES

Max. digging depth with standard arm (optional arm)	mm	2681 (2880)
Max. dumping height with standard arm (optional arm)	mm	3490 (3665)
Bucket breaking force (standard arm) ISO 6015	daN	1600
Arm breaking force (standard arm) ISO 6015	daN	1000
Traction force	daN	2200
Specific ground pressure	kg/cm <sup>2</sup>	0.39
Max. slope	60% - 30°	

## DIMENSIONS

Maximum width	mm	990 - 1300
Total height	mm	2395
Rear rotation radius	mm	950
Digging arm length std (optional)	mm	1250 (1450)
Tracks width	mm	230
Rollers number (for each side)	n°	3

## FILLINGS

Fuel tank	lt	20
Hydraulic oil tank	lt	16
Hydraulic circuit capacity	lt	25
Cooling system capacity	lt	4
Engine oil	lt	4.4

## CONTROLS

Boom, dipper stick, bucket and turret swing	2 pilot joysticks
Two-Pieces-Boom	electroproportional roller on right joystick
Track movements (including counter-rotation)	2 pilot levers
Dozer blade	pilot lever
Priority auxiliary system AUX 1 (single or double effect)	electroproportional roller on right joystick
Boom swing	electroproportional roller on left joystick

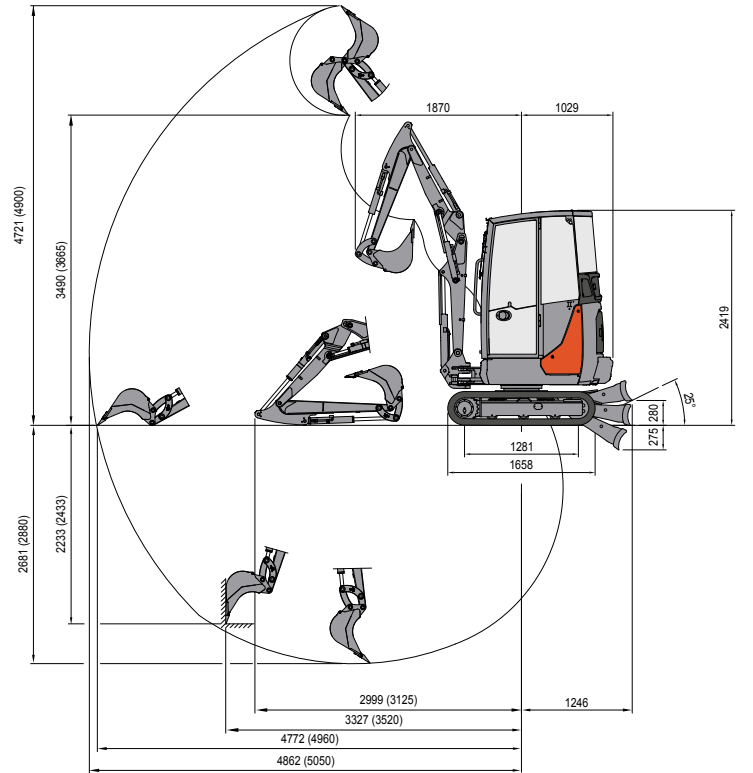

Standard dipper stick L=1.250  
(Optional dipper stick L=1.450)

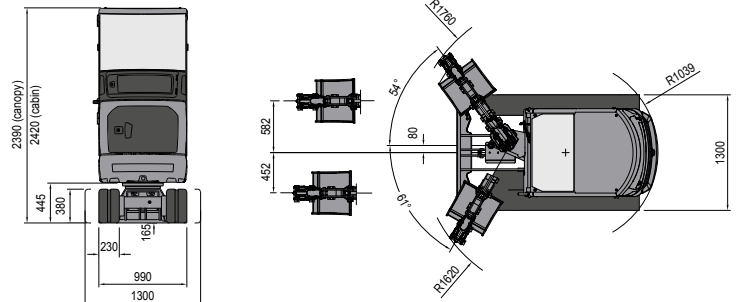

## LIFTING CAPACITY

Opening arm from the rotation's center (m)  
Lifting capacity (kg) at 1.0 m height

	2	3	MAX
Frontal and lowered dozer blade	*900	*440	*400
Frontal and lifted dozer blade	530	270	170
Lateral, open undercarriage	*450	230	150

\* Indicates the hydraulic load limit.

The lifting capacity is based on the ISO 10567 and it does not exceed more than the 75% of static tipping load or more than the 87% of the hydraulic lifting capacity of the machine.

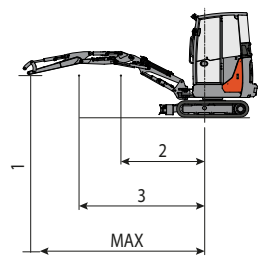

 **EUROCOMACH®**