

WHEEL MILLING MACHINES

FRE 450 T - FRE 600 T

Wheel milling machines equipped with a standard wheel with cement teeth, complete with:

- Monolithic toothed wheel
- Hydraulic depth adjustment
- Hydraulic sideshifter with universal couplings
- Oversized left-hand strip for moving the material up to 40 cm from the excavation (for FRE 600 T only)
- Performer attachments

Ideal for connection to skid steers with 3 hydraulic flow lines (add valve V3) or with 5 hydraulic flow lines.

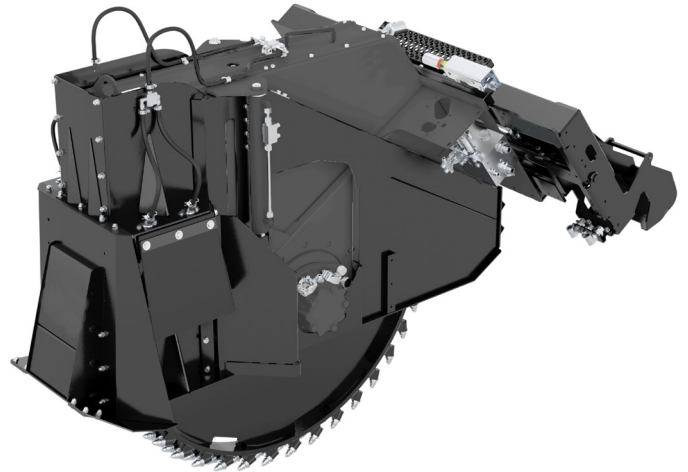

Model	FRE 450 T	FRE 600 T
Operating depth (mm)	150-450	200-600
Standard wheel width (mm)	80-160	90-160
Required oil pressure (bar)	300-180	300-180



ACCESSORIES:

Model	FRE 450 T	FRE 600 T
Electro-hydraulic valve essential for skid steers with only 3 hydraulic flow lines, including electrical system		
Excavation emptying device		
Additional right-hand strip		
Additional left-hand strip		
Right and left lateral latch kit		
Performance indicator "Performer"		
Water spray system kit with sprayers for mounting on skid steer roof. 110 l tank with 12 V electric pump, filter, regulating valve and quick coupling		

WHEEL MILLING MACHINES

FRE 450 TS - FRE 600 TS

Base wheel milling machines without sectors, complete with:

- Hydraulic depth adjustment
- Hydraulic sideshifter with universal couplings
- Oversized left-hand strip for moving the material up to 40 cm from the excavation
- Performance indicator

Ideal for connection to skid steers with 3 hydraulic flow lines (add valve V3) or with 5 hydraulic flow lines.

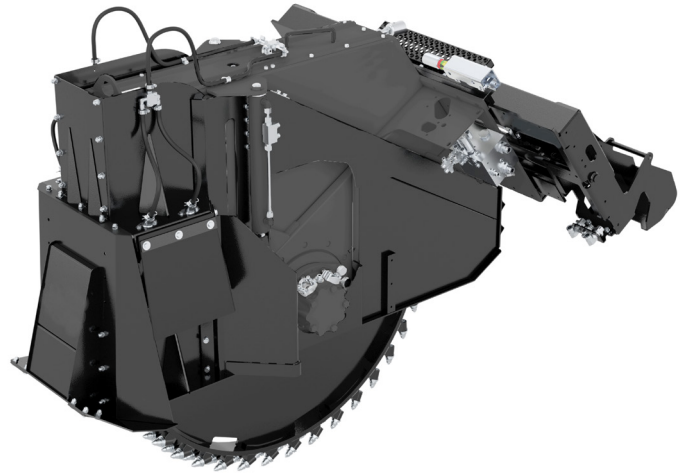

Model	FRE 450 TS	FRE 600 TS
Operating depth (mm)	150-450	200-600
Standard wheel width (mm)	80-160	90-160
Required oil pressure (bar)	300-180	300-180

Widening sectors (mandatory)	FRE 450 TS	FRE 600 TS
	S 50	
	S 80	
	S 100	
	S 130	
	S 160	
	S 200	



ACCESSORIES:

Model	FRE 450 TS	FRE 600 TS
Electro-hydraulic valve essential for skid steers with only 3 hydraulic flow lines, including electrical system		
Excavation emptying device		
Additional right-hand strip		
Additional left-hand strip		
Right and left lateral latch kit		
Performance indicator "Performer"		
Water spray system kit with sprayers for mounting on skid steer roof. 110 l tank with 12 V electric pump, filter, regulating valve and quick coupling		

WHEEL SAWS

FRE 350 RW

The RW350 wheel saw has been specifically developed for small-section trenches and fiber optic cable installation on hard surfaces such as asphalt and concrete.

It is prepared for the installation on machines with 3 hydraulic lines.

Standard equipped with:

- Manual hydraulic depth
- Hydraulic lateral shift
- Manual scraper for side discharge of materials
- Direct drive motor with the wheel

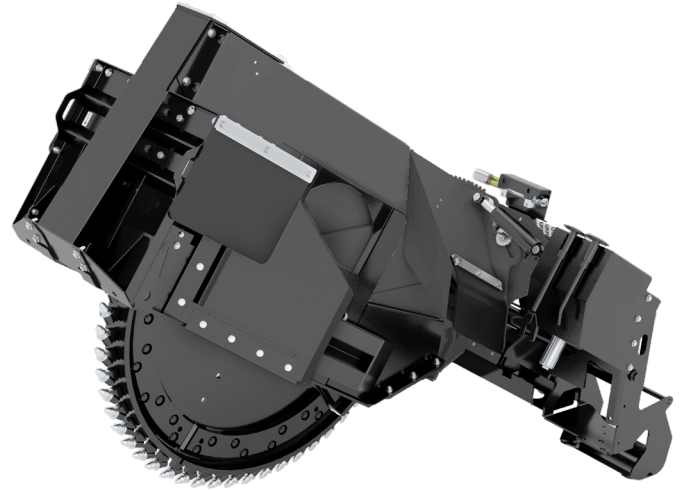

Model	FRE 350 RW
Performance indicator "Performer"	
Water spraying system with nebulizers for mounting on skid steer roof	
Price (with 25mm wheel)	
Price (with 30mm wheel)	
Price (with 40mm wheel)	
Price (with 50mm wheel)	
Price (with 80mm wheel)	



OPTIONALS:

Model	FRE 350 RW
Electro-hydraulic valve necessary for skid-steer-loader with only 3 hydraulic lines. Electrical device included	
Trench clearing device	
Additional right hand side material clearing slide	
Additional left hand side material clearing slide	
Right and left hand side closing kit	
Pressure gauge - "Performer"	
Water spraying system with nebulizers for mounting on skid steer roof including 110 l tank with 12 V electric pump, filter, regulating valve and quick release	

WHEEL MILLING MACHINES

FRE 500 RW

Wheel saw with removable and interchangeable sectors complete with:

- Hydraulic depth regulation
- Hydraulic side tilt with universal coupling
- Lateral discharge of material

Ideal for installation on skid loaders with 3 hydraulic lines (add V3 valve) or 5 hydraulic lines.

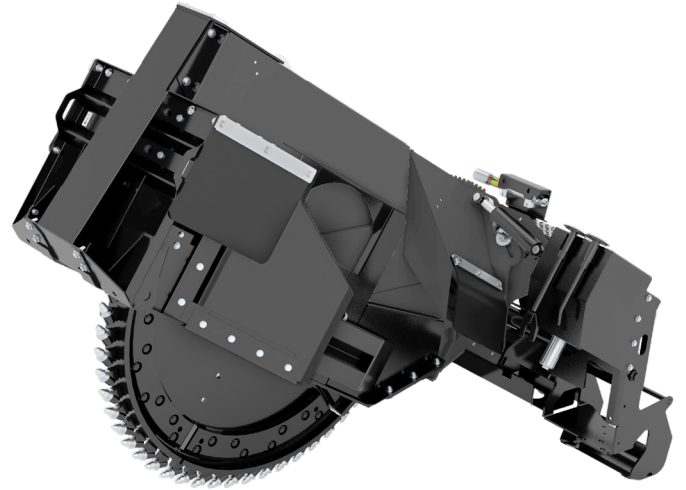

Model	FRE 500 RW
Operating depth (mm)	250-500
Standard wheel width (mm)	90-160
Required oil pressure (bar)	300-160

Widening sectors (mandatory)	FRE 500 RW
	S 50
	S 80
	S 100
	S 120



ACCESSORIES:

Model

FRE 500 RW

Electro-hydraulic valve essential for skid steers
with only 3 hydraulic flow lines, including electrical system

Performance indicator "Performer"

Right side latch kit

Water spray system kit with sprayers for mounting on skid steer roof. 110 l tank with 12 V electric pump, filter, regulating valve and quick coupling

WHEEL MILLING MACHINES

FRE 500 RWA

Wheel milling machine with removable and interchangeable sectors with:

- Hydraulic depth adjustment
- Hydraulic sideshifter with universal couplings
- Transverse hydraulic tilting
- Performance indicator
- Lateral discharge of material

Ideal for connection to skid steers with 3 hydraulic flow lines (add valve V3) or with 5 hydraulic flow lines.

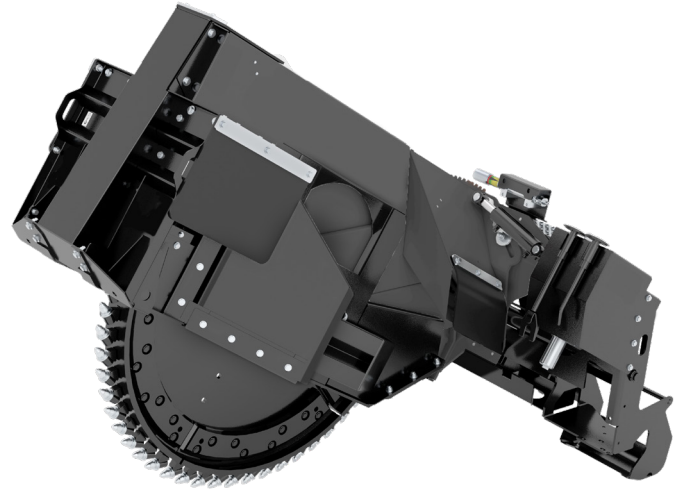

Model	FRE 500 RWA
Operating depth (mm)	250-500
Standard wheel width (mm)	90-160
Required oil pressure (bar)	300-160

Widening sectors (mandatory)	FRE 500 RWA
	S 50
	S 80
	S 100
	S 120



ACCESSORIES:

Model

FRE 500 RWA

Electro-hydraulic valve essential for skid steers with only 3 hydraulic flow lines, including electrical system

Performance indicator "Performer"

Right side latch kit

Water spray system kit with sprayers for mounting on skid steer roof. 110 l tank with 12 V electric pump, filter, regulating valve and quick coupling
