

# 15zT



Concrete solutions. Always.

Engine 3TNV70

Engine power 12,0 kW - 15,4 HP

Transport weight 1.580 - 1.690 kg

 **EUROCOMACH**<sup>®</sup>

# 15ZT

Transport weight with canopy (without bucket and operator)	kg	1.580
Transport weight with cabin (without bucket and operator)	kg	1.690
Operating weight ISO 6016 with canopy (with bucket 35 kg and operator 75 kg)	kg	1.690
Operating weight ISO 6016 with cabin (with bucket 35 kg and operator 75 kg)	kg	1.800
Travelling speed (AUTO TWO SPEED)	km/h	1a : 0 ÷ 2,2 / 2a : 0 ÷ 4,1
Slew speed	rpm	10,5

## ENGINE

Type	YANMAR 3TNV70 - STAGE 5	
Max. Power (2.200 rpm)	kW - HP	12,0 - 15,4
Displacement	cc	854
Number of cylinders	n°	3
Cooling	Liquid	
Consumption	lt/h	2,4
Alternator	V (A)	12 (40)
Battery	V (Ah)	12 (65)

## HYDRAULIC SYSTEM

Pump type	variable flow	
Pump displacement	cc	8 + 8 + 6,6
Pump capacity	lt/min	16 + 16 + 13,1
Max. circuit calibration pressure	bar	220
Auxiliary system (max pressure): AUX 1 single or double effect	lt/min (bar)	29,1 (205)

## PERFORMANCES

Max. digging depth	mm	2.020
Max. dumping height	mm	2.340
Bucket breaking force ISO 6015	daN	1.500
Arm breaking force ISO 6015	daN	1.080
Traction force	daN	1.700
Specific ground pressure	kg/cm <sup>2</sup>	0,31
Max. slope	60% - 30°	

## DIMENSIONS

Maximum width	mm	990 - 1.250
Total height	mm	2.370
Rear rotation radius	mm	650
Digging arm length	mm	950
Tracks width	mm	230
Rollers number (for each side)	n°	3

## FILLINGS

Fuel tank	lt	25
Hydraulic oil tank	lt	20
Hydraulic circuit capacity	lt	29
Cooling system capacity	lt	4,5
Engine oil	lt	2,4

## CONTROLS

Boom, dipper stick, bucket and turret swing	2 pilot joysticks
Track movements (included counter rotation)	2 mechanical levers
Dozer blade	pilot lever
Auxiliary system AUX 1 (single or double effect)	left pedal
Boom swing	right pedal

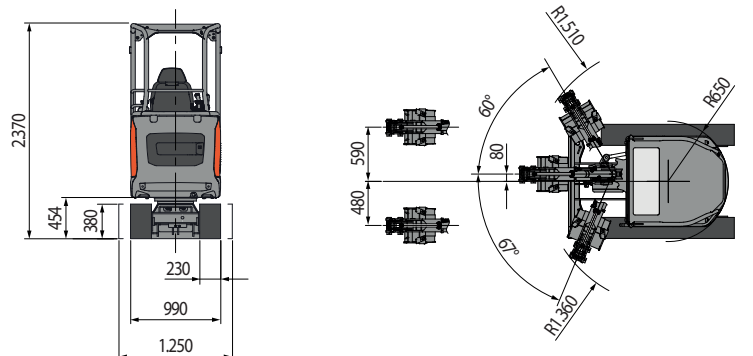
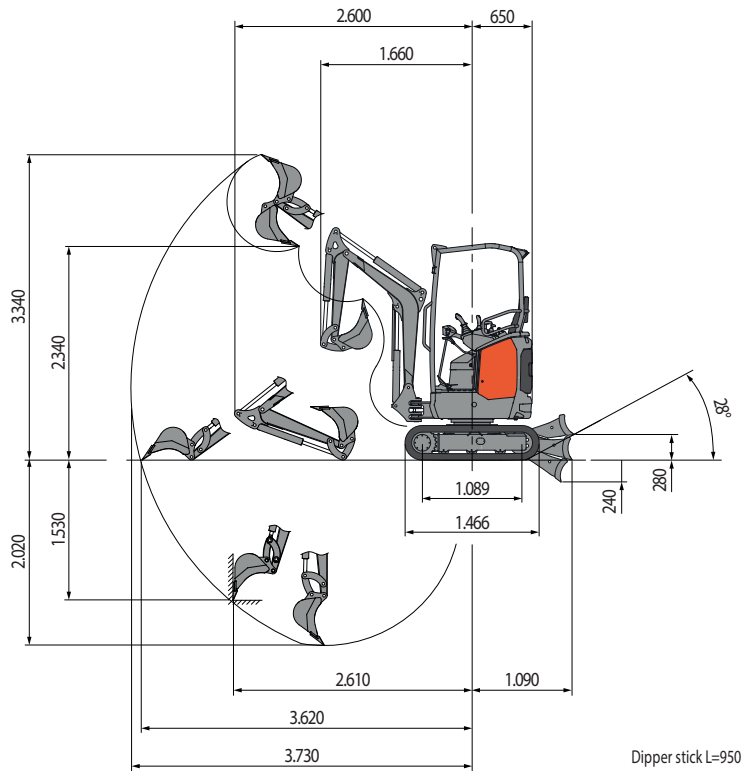

## LIFTING CAPACITY

Opening arm from the rotation's center (m)  
Lifting capacity (kg) at 1.0 m height

	2	3	MAX
Frontal and lowered dozer blade	*720	*480	*460
Frontal and lifted dozer blade	300	160	150
Lateral, open undercarriage	340	190	170

\* Indicates the hydraulic load limit.

The lifting capacity is based on the ISO 10567 and it does not exceed more than the 75% of static tipping load or more than the 87% of the hydraulic lifting capacity of the machine.

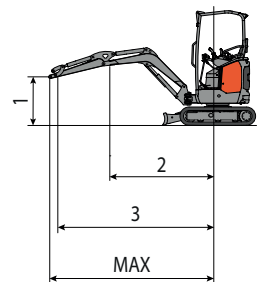

 **EUROCOMACH**<sup>®</sup>