

ETL 200



Concrete solutions. Always.

Engine 4TNV98T

Engine power 63,9 kW - 86,9 HP

Operating Weight 5.470

 **EUROCOMACH**[®]

Operating weight with rubber tracks	kg	5.470
-------------------------------------	----	-------

ENGINE		
Type	YANMAR 4TNV98T EU Stage IIIA EPA Tier 3	
Max Power (2.600 rpm)	kW - HP	63,9 - 86,9
Max torque	Nm	296,1 (1.850 rpm)
Displacement	cc	3.319
Number of cylinders	n°	4
Cooling	water	
Consumption	lt/h	9
Alternator	V (A)	12 (80)
Battery	V (Ah)	12 (100/850)

HYDRAULIC SYSTEM		
Pump type	N° 1 with variable displacement axial piston pumps with load sensing REXROTH	
Pump capacity	lt/min	160
Max. circuit calibration pressure	bar	280
High Flow System (standard): Max capacity Max pressure	lt/min bar	160 280

TRANSMISSION		
Type	Hydrostatic with electro-hydraulic tandem pump and radial pistons REXROTH gearboxes	
Travelling speed	km/h	1 ^a : 0 ÷ 6,2 / 2 ^a : 0 ÷ 12,5
Max Traction force	daN	5.100
Tracks width with rubber tracks	mm	450

BRAKES		
Service brakes	Hydrostatic	
Parking brakes	Negative with multiple disks into oil bath, integrated on the gearboxes at electrohydraulic control	
Emergency brakes	Electrohydraulic control, acting on parking brakes (integrated on the gearboxes)	

PERFORMANCES		
Upsetting load (ISO 14397)	kg	5.143
Operating load (no more than 50% of tipping load)	kg	2.572
Operating load (ISO 14397, no more than 35% of tipping load)	kg	1.800
Teeth breakout force	daN	3.985
Standard bucket capacity	m ³	0,64
Standard bucket width	mm	2.110
Ground bearing pressure with rubber tracks	kg/cm ²	0,34
Max slope	60% - 30°	

FILLINGS		
Fuel tank	lt	110
Hydraulic oil tank	lt	55
Hydraulic circuit capacity	lt	93
Cooling system capacity	lt	12
Engine oil	lt	6

CONTROLS		
Type	Ergonomic joystick with electronic controls and onboard safety lock	
Translation	Electro-hydraulic control on left hand joystick	
Services	Electric control with right hand joystick for lifting and bucket	
Lifting mechanism	Vertical lifting boom with a standard self-levelling system for the bucket (only for boom rising)	

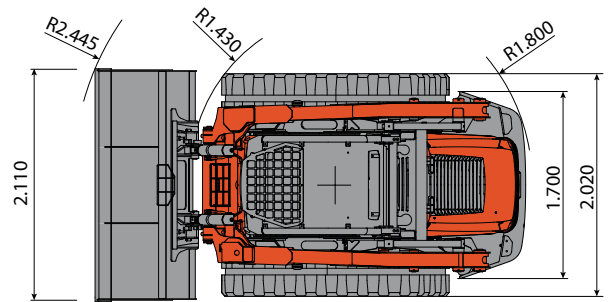
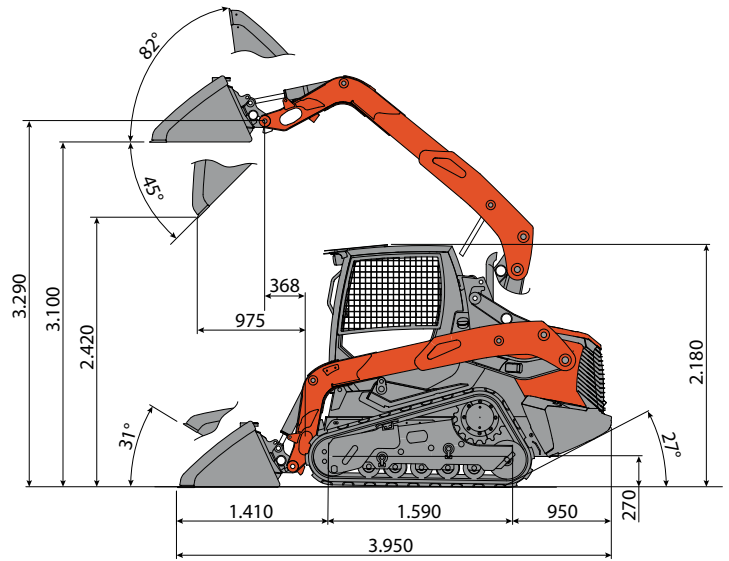

Tracked undercarriage with steering roller system

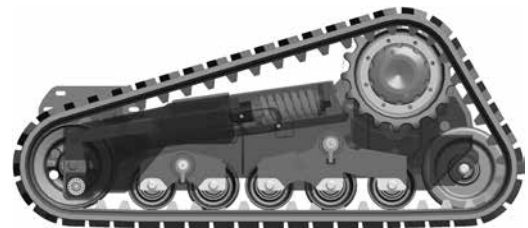

The tracked undercarriages are endowed with a steering rollers system to allow a higher comfort for the worker over rough surfaces.

- The ROPS (ISO 3471) – FOPS (ISO 3449) engineer standards manufactured cab or canopy.
- Front and rear lights for night-road use and working.