

# 85SB



Concrete solutions. Always.

Engine 4TNV98CT

Engine Power 53.7 kW - 73 HP

Operating Weight 8830 kg

 **EUROCOMACH**<sup>®</sup>

# 85SB

Transport weight with rubber tracks	kg	8500
Transport weight with steel tracks	kg	8900
Travel speed (AUTO TWO SPEED)	km/h	1a: 0 ÷ 2,6 / 2a: 0 ÷ 5,2
Upper frame rotation speed	rpm	9.5

## ENGINE

Type	Yanmar 4TNV98CT Stage V - Tier 4 Final	
Max. Power (2.100 rpm)	kW - HP	53.7 - 73
Displacement	cc	3319
Cylinders	n°	4
Cooling	Liquid	
Fuel consumption (65% max power)	l/h	9.3
Alternator	V (A)	12 (80)
Battery	V (Ah/A)	12 (100/900)

## HYDRAULIC SYSTEM

Circuit Type	eHPQ Rexroth system	
Pump type	1 electronic pump (EOC) with variable flow rate + 1 gear pump on engine PTO (FAN DRIVE)	
Pump displacement	cc	100 + 14
Pump capacity	l/min	192 + 27
Max. circuit calibration pressure	bar	290
Flow rate (max pressure) auxiliary system AUX1	l/min (bar)	100 (200)
Flow rate (max pressure) auxiliary system AUX2	l/min (bar)	70 left - 90 right (290)
Flow rate (max pressure) auxiliary system AUX3	l/min (bar)	50 left - 50 right (250)

## PERFORMANCES

Digging depth with standard arm (long arm)	mm	3670 (4020)
Max. dumping height with standard arm (long arm)	mm	5180 (5420)
Bucket breaking force ISO 6015	daN	6300
Standard arm breakout force ISO 6015 (long arm)	daN	4350 (3850)
Traction force	daN	7960
Specific ground pressure	kg/cm <sup>3</sup>	0.39
Max. slope	% / °	60 / 30

## DIMENSIONS

Max. width	mm	2320
Total height with FOPS level 2 (without)	mm	2760 (2680)
Rear rotation radius	mm	1220
Digging arm length std (optional)	mm	1760 (2110)
Tracks width	mm	450
Rollers number (for each side)	n°	5/1 (rubber track) 6/1 (steel track)

## FILLINGS

Fuel tank	lt	105
Hydraulic oil tank	lt	85
Hydraulic system capacity	lt	135
Cooling system capacity	lt	23
Engine oil	lt	10

## CONTROLS

Boom, dipper stick, bucket and upper frame swing	2 CAN-bus electronic joysticks
Tracks movement (included counter rotation)	2 CAN-bus electronic levers
Dozer blade	1 CAN-bus electronic joystick
AUX1 auxiliary system	1 CAN-bus electronic roller on right joystick
AUX2 auxiliary system	1 CAN-bus electronic roller on right joystick
AUX3 auxiliary system	1 CAN-bus electronic roller on left joystick

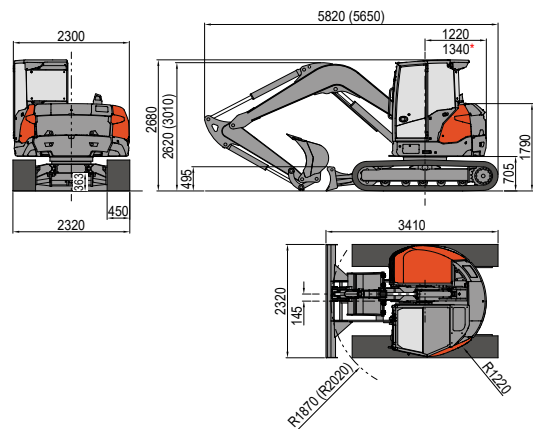
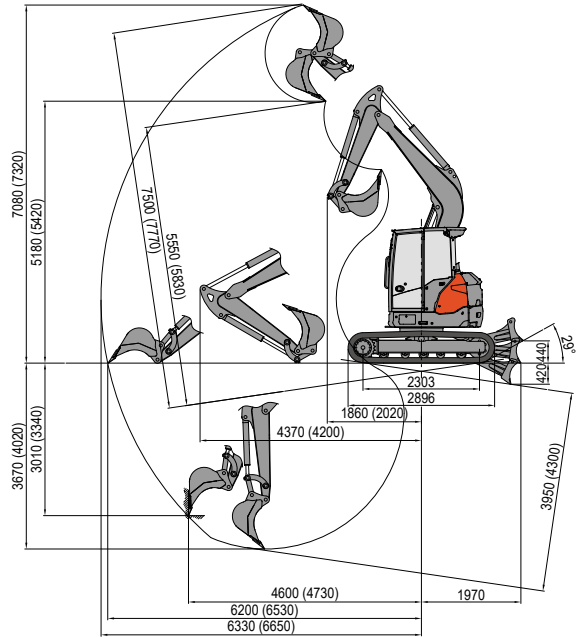

## LIFTING CAPACITY

Opening arm from the rotation's center (m) Lifting capacity (kg) at 1 m height

	3	4	5	MAX
Frontal and lowered dozer blade	*4420	*3250	*2610	*2420
Frontal and lifted dozer blade	3540	2270	1630	1470
Lateral	2750	1820	1320	1200

\* Indicates the hydraulic load limit.

The lifting capacity is based on the ISO 10567 and it does not exceed more than the 75% of static tipping load or more than the 87% of the hydraulic lifting capacity of the machine.

 **EUROCOMACH**