

# 20TL



Concrete solutions. Always.

**Engine 4TNV98TCT**

**Engine power 53,7 kW - 73,0 HP**

**Operating Weight 5.470 Kg**

 **EUROCOMACH®**

# 20TL

Operating weight with rubber tracks	kg	5.470
-------------------------------------	----	-------

## ENGINE

Type	YANMAR 4TNV98TCT - STAGE 5	
Max Power (2.600 rpm)	kW - HP	53,7 - 73,0
Max torque	Nm	215 (1.625 rpm)
Displacement	cc	3.319
Number of cylinders	n°	4
Cooling	water	
Consumption	lt/h	11
Alternator	V (A)	12 (80)
Battery	V (Ah)	12 (100/850)

## HYDRAULIC SYSTEM

Pump type	N° 1 with variable displacement axial piston pumps with load sensing REXROTH	
Pump capacity	lt/min	160
Max. circuit calibration pressure	bar	280
High Flow System (standard): Max capacity Max pressure	lt/min bar	160 280

## TRANSMISSION

Type	Hydrostatic with electro-hydraulic tandem pump and radial pistons REXROTH gearboxes	
Travelling speed	km/h	1 <sup>a</sup> : 0 ÷ 6,2 / 2 <sup>a</sup> : 0 ÷ 12,5
Max Traction force	daN	5.100
Tracks width with rubber tracks	mm	450

## BRAKES

Service brakes	Hydrostatic	
Parking brakes	Negative with multiple disks into oil bath, integrated on the gearboxes at electrohydraulic control	
Emergency brakes	Electrohydraulic control, acting on parking brakes (integrated on the gearboxes)	

## PERFORMANCES

Upsetting load (ISO 14397)	kg	5.143
Operating load (no more than 50% of tipping load)	kg	2.572
Operating load (ISO 14397, no more than 35% of tipping load)	kg	1.800
Bucket breaking force	daN	3.985
Standard bucket capacity	m <sup>3</sup>	0,64
Standard bucket width	mm	2.090
Ground bearing pressure with rubber tracks	kg/cm <sup>2</sup>	0,34
Max slope	60% - 30°	

## FILLINGS

Fuel tank	lt	100
Hydraulic oil tank	lt	55
Hydraulic circuit capacity	lt	93
Cooling system capacity	lt	12
Engine oil	lt	10,2

## CONTROLS

Type	Ergonomic joystick with electronic controls and onboard safety lock
Translation	Electro-hydraulic control on left hand joystick
Services	Electric control with right hand joystick for lifting and bucket
Lifting mechanism	Vertical lifting boom with a standard self-levelling system for the bucket (only for boom rising)

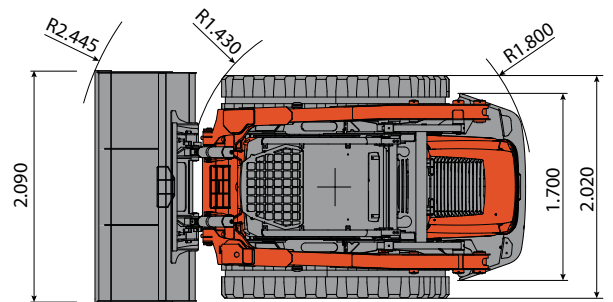
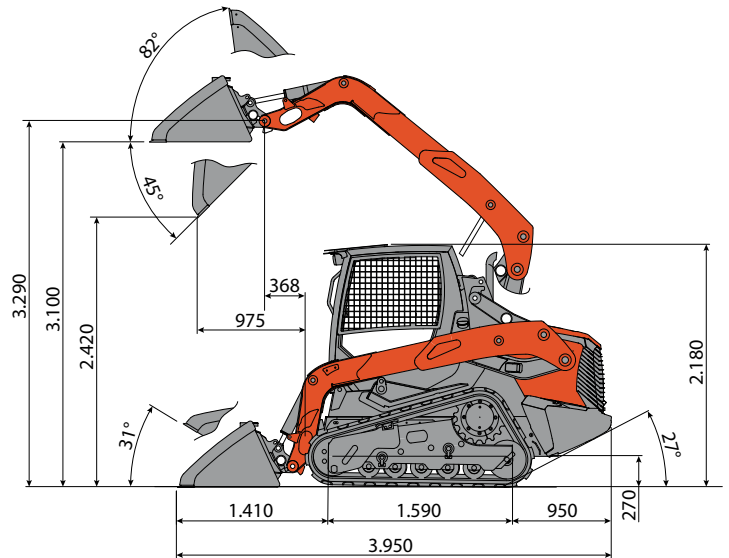

Tracked undercarriage with steering roller system

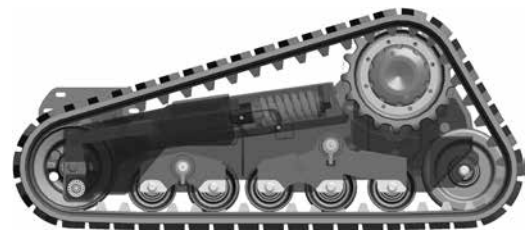

The tracked undercarriages are endowed with a steering rollers system to allow a higher comfort for the worker over rough surfaces.

- Homologation for road traffic (only Italy).
- The ROPS (ISO 3471) – FOPS (ISO 3449) engineer standards manufactured cab or canopy.
- Front and rear lights for night-road use and working.

 **EUROCOMACH®**