

28zT



Concrete solutions. Always.

Engine D1703-M-DI-E4B

Engine power 18,2 kW - 24,7 HP

Operating Weight 2.700 - 2.850 kg

 **EUROCOMACH®**

28ZT

Operating weight with canopy (with rubber tracks)	kg	2.700
Operating weight with cabin (with rubber tracks)	kg	2.850
Travelling speed (AUTO TWO SPEED)	km/h	1a : 0 ÷ 2,5 / 2a : 0 ÷ 4,6
Slew speed	rpm	10

ENGINE

Type	KUBOTA D1703-M-DI-E4B-STAGE 5	
Max. Power (2.200 rpm)	kW - HP	18,2 - 24,7
Displacement	cc	1.647
Number of cylinders	n°	3
Cooling	Liquid	
Consumption	lt/h	3,5
Alternator	V (A)	12 (40)
Battery	V (Ah)	12 (80)

HYDRAULIC SYSTEM

Circuit Type	Load Sensing closed center system with "Flow Sharing" control valve	
Pump type	1 LS variable pump + 1 gear pump	
Pump displacement	cc	48 + 5
Pump capacity	lt/min	105 + 10
Max. circuit calibration pressure	bar	250
Auxiliary systems (max pressure): AUX 1 single or double effect with priority AUX 2 double effect (optional)	lt/min (bar)	50 (200) 35/20 (250)

PERFORMANCES

Max. digging depth with standard arm (optional arm)	mm	2.650 (2.850)
Max. dumping height with standard arm (optional arm)	mm	3.100 (3.220)
Bucket breaking force (standard arm) ISO 6015	daN	3.500
Arm breaking force (standard arm) ISO 6015	daN	1.750
Traction force	daN	3.400
Ground bearing pressure with rubber tracks and canopy (with cabin)	kg/cm ²	0,29 (0,31)
Max. slope	60% - 30°	

DIMENSIONS

Maximum width	mm	1.550
Total height	mm	2.530
Rear rotation radius	mm	770
Digging arm length std (optional)	mm	1.200 (1.400)
Tracks width	mm	280
Rollers number (for each side)	n°	4/1

FILLINGS

Fuel tank	lt	46
Hydraulic oil tank	lt	30
Hydraulic circuit capacity	lt	54
Cooling system capacity	lt	7,5
Engine oil	lt	7

CONTROLS

Boom, dipper stick, bucket and turret swing	2 pilot joysticks
Tracks movement (included counter rotation)	2 pilot levers
Dozer blade	pilot lever
Priority auxiliary system with holding function AUX 1 (single or double effect)	electroproportional switch on right joystick
Auxiliary system AUX 2 (double effect)	electroproportional switch on left joystick
Boom swing	electroproportional switch on left joystick

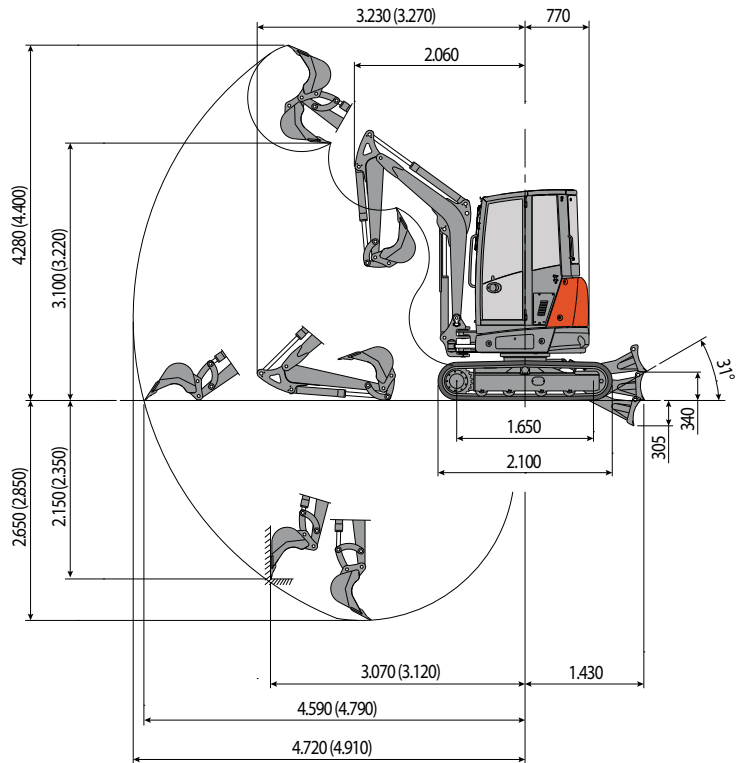

Standard dipper stick L=1.200
(Optional dipper stick L=1.400)

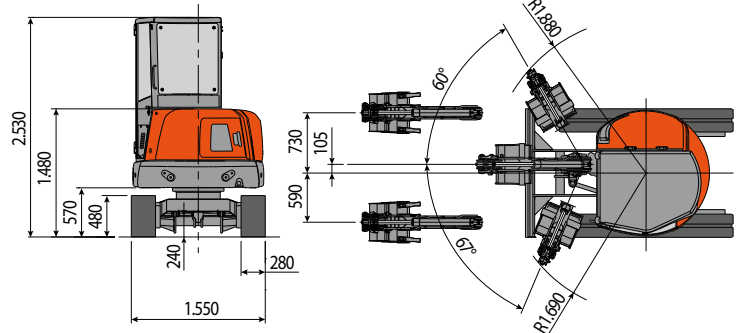

LIFTING CAPACITY

Opening arm from the rotation's center (m)
Lifting capacity (kg) at 1.0 m height

	3	4	MAX
Frontal and lowered dozer blade	*890	*680	*670
Frontal and lifted dozer blade	600	390	380
Lateral	420	280	270

* Indicates the hydraulic load limit.

The lifting capacity is based on the ISO 10567 and it does not exceed more than the 75% of static tipping load or more than the 87% of the hydraulic lifting capacity of the machine.

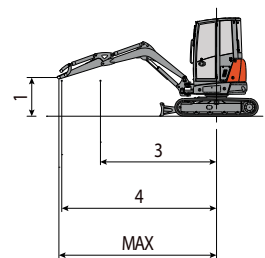

 **EUROCOMACH**